

Jumboweigher



Features and benefits:

- Large bright LED display
- High accuracy
- Aluminium housing
- Power saving mode
- Push button tare
- Hold function
- Large keys make operation simple even if wearing gloves



A popular choice among steel service centres and other heavy industrial applications, the Jumboweigher crane scale from Straightpoint offers a cost-effective alternative to its more expensive rivals yet a safe option over low cost crane weighers. The Jumboweigher series of crane scales offers high capacity, quality, accuracy, and safety at low capacity prices and are utilised worldwide in a variety of manufacturing and industrial applications.

As with all Straightpoint products each Jumboweigher crane scale receives superior electronics, excellent build quality and certified calibration and proof testing. The heavy duty crane scale is extremely accurate, and is manufactured from quality materials, featuring a high strength aluminium alloy outer housing.

Each unit is equipped with a large and bright LED display that can be easily read even in direct sunlight. The simple to use remote features oversized buttons for use with gloved hands and provides for control of tare and hold functions. Battery charging intervals are extended by the standby power saving mode as well as the automatic shut off feature. As with all Straightpoint products each Jumboweigher is safety tested and is supplied with certification of calibration and proof testing.

If you are looking for a high quality, cost-effective crane scale and are unwilling to give up features and safety, look no further than the Jumboweigher crane scale from Straightpoint.

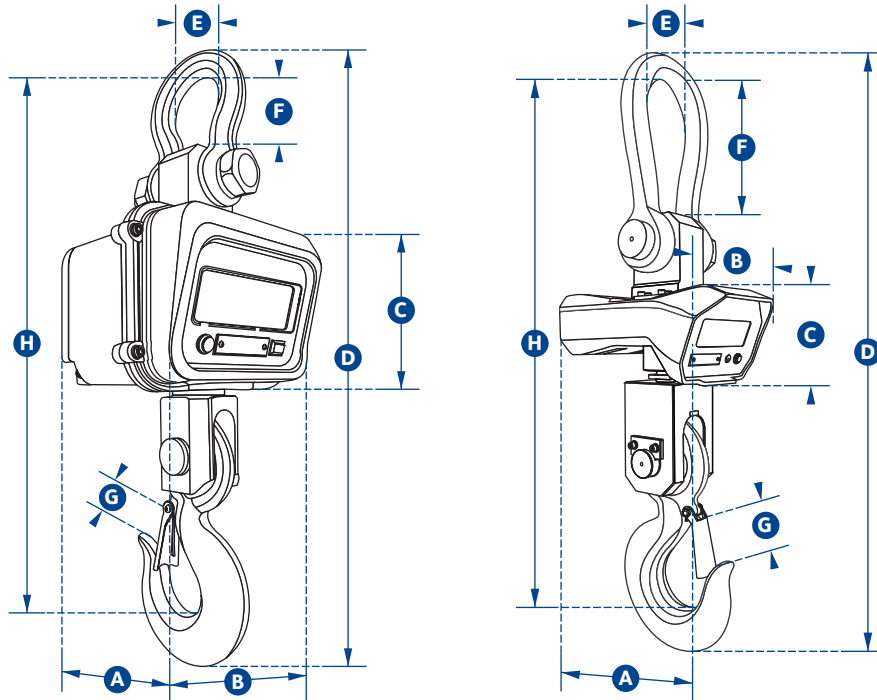

Part Number	JW5T	JW10T	JW20T
Capacity	5000kg	10000kg	20000kg
	11000lb	22000lb	44000lb
Resolution	2kg	5kg	10kg
	5lb	10lb	20lb
Units		kg	
		lb	
Weight	18kg	29kg	75kg
	40lb	64lb	165lb
Safety Factor		5:1	
Battery Type	Internal rechargeable		
Battery Life	20hrs		
Display Type	30mm / 1.18" LED		
Operating Temp	-10°C to +40°C / 14°F to 104°F		
Accuracy	±0.1% of full scale		
Protection	IP54 / NEMA 3		
Dimension A	195	195	355
	7.68"	7.68"	13.98"
Dimension B	255	255	230
	10.04"	10.04"	9.06"
Dimension C	180	180	165
	7.09"	7.09"	6.50"
Dimension D	715	780	1115
	28.15"	30.71"	43.90"
Dimension E	72	90	140
	2.83"	3.54"	5.51"
Dimension F	90	110	230
	3.54"	4.33"	9.06"
Dimension G	36	50	70
	1.42"	1.97"	2.76"
Dimension H	595	660	980
	23.43"	25.98"	38.58"